

# Instruction Manual

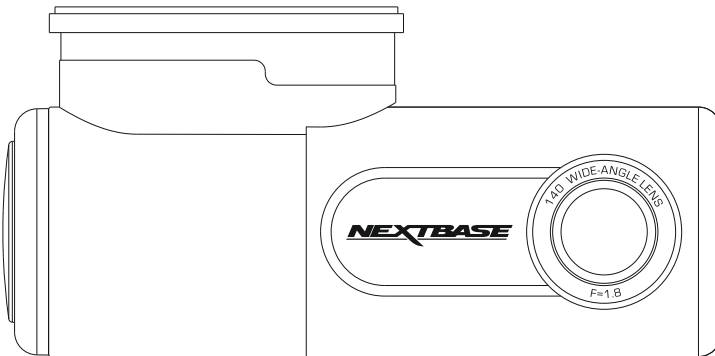

## TABLE OF CONTENTS

TABLE OF CONTENTS .....	02
INTRODUCTION TO USING A DASH CAM .....	03
PRECAUTIONS .....	04
CAUTIONS ON USING THIS PRODUCT .....	04
PRODUCT SPECIFICATION .....	05
PACKAGE CONTENTS .....	06
PARTS & CONTROLS .....	07
IN VEHICLE INSTALLATION .....	12
DRIVEGUARD™ APP	
INTRODUCTION .....	20
VEHICLE INSURANCE DETAILS .....	21
CONNECT YOUR DEVICE .....	23
HOME SCREEN .....	24
DOWNLOADING RECORDINGS (iOS) .....	26
DOWNLOADING RECORDINGS (ANDROID) .....	27
EDITING RECORDINGS .....	28
SHARING RECORDINGS .....	30
INCIDENT REPORTING .....	31
DASH CAM SETTINGS .....	35
HOW TO FORMAT THE SD CARD .....	41
PC CONNECTION .....	42
DECLARATION OF CONFORMITY .....	43
TROUBLE SHOOTING .....	44

## INTRODUCTION TO USING A DASH CAM

The Nextbase range of Dash Cams have been designed specifically with ease of use in mind, it is recommended NOT to change the default settings, which have been carefully selected to give the best performance for day to day use.

### Basic operation.

The Dash Cam is set to record video, in files 1 minute in length. This means that each video file is a manageable size should you need to download and send to your insurance company. Eventually your MicroSD card will fill up with video files but don't worry, the camera automatically deletes the oldest file to make space for new recordings. This way you never run out of space and have plenty of driving historical evidence saved.

Typically, a 16Gb card will store the last 2 hours of driving footage.

### Automatic Start / Stop Technology.

The Dash Cam senses power supplied to the cigarette lighter socket as soon as the vehicle ignition is turned on and will start to record automatically.

When the ignition is turned off, the Dash Cam will perform an automatic shutdown process.

### 1. Tips for capturing best video footage:

- 1.1 Position the Dash Cam in the centre of the windscreen and ideally behind the rear view mirror so it is not an obstruction to the driver's field of view
- 1.2 Reduce the amount of sky in the picture, by angling the view of the camera towards the road. Too much sky will make the road appear darker due to the automatic exposure compensation.
- 1.3 Remove unnecessary items from your dashboard. If objects are placed on your dashboard these can cause reflections to be seen on the windscreen and these reflections may be captured during recording.

### 2. Tips for stable memory card performance:

- 2.1 Periodically format the memory card. Every 2-3 weeks we recommend that you reformat the memory card. This will wipe any files from the card and set it up afresh for continued use with your Dash Cam.  
Of course, you should only do this AFTER you've downloaded any files from the card that you may want to keep, as formatting the card will remove all content.
- 2.1 Format your memory card using the Dash Cam, this will make sure that the card is structured specifically for your camera.
- 2.2 Switch off the Dash Cam before removing or inserting the SD memory card, to prevent the chance of damage being caused to the memory card or the files stored upon it.

## PRECAUTIONS

Please read this manual carefully before operation and keep it for future reference. It will be helpful should you encounter any operational problem.

**WARNING:** Do not expose this product to rain, moisture or water under any circumstances, doing so may result in the risk of electric shock or fire.

**CAUTION:** To reduce the risk of electric shock, do not perform any servicing other than that contained in the instruction manual unless you are qualified to do so.

Have the unit serviced by a qualified service technician if;

The Unit has been exposed to rain or water.

The unit does not seem to operate normally.

The unit exhibits a marked change in performance.

**CHOKING** Some Products may contain components that are small enough to be swallowed.

**HAZARD:** Please keep out of reach of children.

**WEEE:** Disposal of Waste Electrical and Electronic Equipment and/or Battery by users in private households in the European Union.



This symbol on the product or on the packaging indicates that this cannot be disposed of as household waste. You must dispose of your waste equipment and/or battery by handing it over to the applicable take-back scheme for the recycling of electronic equipment and/or batteries. For more information please contact your local household waste disposal office.

## CAUTIONS ON USING THIS PRODUCT

1. Ensure that the windscreen is free of dirt or grease before placing mount upon it.
2. Do not obscure the view of the road ahead or impede the deployment of any airbags in the event of an accident.
3. When not in use, please disconnect the car adaptor from both the 12/24Vdc outlet in your vehicle.
4. Only clean the device with a soft dry cloth, for tough dirt, apply some neutral detergent diluted in 5 to 6 parts water to a soft cloth.  
Note that alcohol, thinner, benzene etc could cause damage to the paint or coatings.
5. Avoid making contact with the lens as damage may be caused.
6. If required clean the glass lens carefully using spectacle lens cleaning fluid on a soft cloth only.
7. The video recordings made by this Dash Cam are intended for personal use only.
8. Publication of the recordings on Youtube, the internet or other methods are subject to the Data Protection Act and the requirements thereof must be adhered to.  
If the Dash Cam is to be used within a commercial environment, i.e. truck use, then the CCTV regulation apply also, in addition to the Data Protection Act regulations. This includes labelling to identify the use of CCTV is taking place, the omission of Audio recording and informing the relevant authorities of who controls the data.
9. Whilst driving, do not adjust the controls of your device as this is a distraction to driving.

## PRODUCT SPECIFICATION

Model Number	NBDVR300W
Power Requirements	5V / 1.5A
Power Supply	12-24Vdc Car Power Cable (supplied) Fuse Type: 20mm / 1.5A Output: 5Vdc
Sensor Resolution	2.12M Pixel
Lens - Type / Angle / Aperture	6G / 140° / F1.8
Recording Resolution	1920 x 1080 @ 30fps
Card Reader	8 - 128GB MicroSD Card
SD Card (Recommended Type)	8 - 128GB MicroSD Card, Class 10 (48MB/s minimum), for best results use a recognized brand
SD Card Recorded file Capacity (based on default settings)	8GB MicroSD = 60 minutes of recording 16GB MicroSD = 120 minutes of recording 32GB MicroSD = 240 minutes of recording 64GB MicroSD = 480 minutes of recording 128GB MicroSD = 960 minutes of recording
Recording Format	.MOV
Unit Dimensions (inc. mount)	W35mm * L96mm * H47mm
Unit Weight (inc. mount)	46g
DriveGuard™ (min req.) Android iOS	V5.1 10.3
Replay 3 (min req.) Windows Mac	Windows7 10.7

## SIMPLIFIED EU DECLARATION OF CONFORMITY

Hereby, Portable Multimedia Limited declares that the radio equipment type NBDVR300W is in compliance with Directive 2014/53/EU. The full text of the EU declaration of conformity is available at the following internet address: <https://www.nextbase.com/certifications/>

## PRODUCT WIRELESS INFORMATION

2400–2483.5 MHz: Wi-Fi (Max 16.3 dBm), BT (Max 6.0 dBm), BLE (Max 6.0 dBm).

## RF EXPOSURE INFORMATION (MPE)

This device meets the EU requirements and the International Commission on Non-Ionising Radiation Protection (ICNIRP) on the limitation of exposure of the general public to electromagnetic fields by way of health protection. To comply with the RF exposure requirements, this equipment must be operated in a minimum of 20 cm separation distance to the user.

## PACKAGE CONTENTS

Please check the contents of your NEXTBASE product.

### Dash Cam & Mount

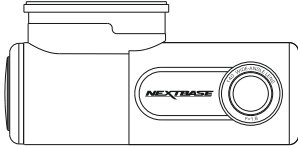

### Car Power Cable

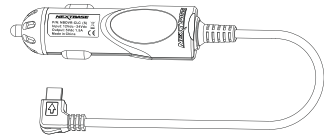

### Window Sticker



### USB Cable

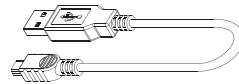

### Quick Start Guide

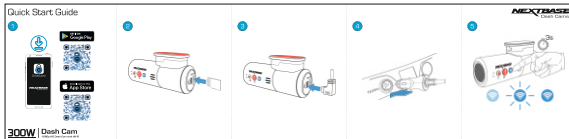

Product appearance may differ slightly to that shown above.

**For Help and Support please call 02920 866 429**

Android is a trademark of Google Inc. in the United States and other countries.  
Mac is a registered trademarks of Apple Inc. in the United States and other countries.  
iOS is a trademark or registered trademark of Cisco in the United States and other countries.  
© 2015 Google Inc. All rights reserved. Google Maps™ mapping service is a trademark of Google Inc.  
Windows is a registered trademark of Microsoft Corporation in the United States and other countries.  
NEXTBASE Replay 3™ is a registered trademark of Portable Multimedia LTD in the United Kingdom.  
NEXTBASE DriveGuard™ is a registered trademark of Portable Multimedia LTD in the United Kingdom.  
microSD™ and the microSD logo are trademarks of SD-3C, LLC.  
Wi-Fi® is a registered mark of Wi-Fi Alliance Corporation.  
Other trademarks and trade names are those of their respective owners.

## PARTS & CONTROLS

Please see below to identify the parts and controls of your Dash Cam.

Front:

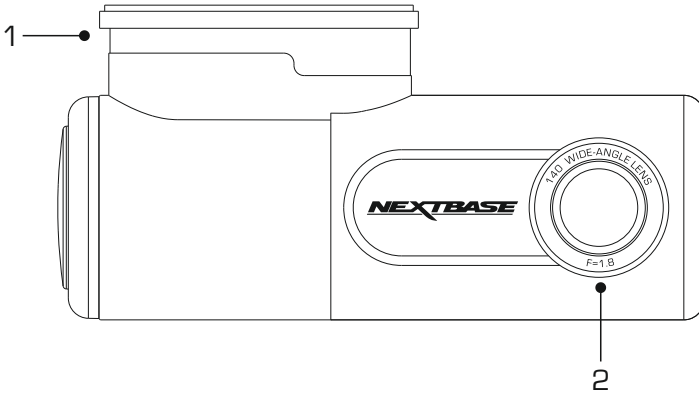

### 1. Mount

The Dash Cam will simply slide on and off the mount.

The mount is attached to the windscreen using the 3M sticker attached to the mount. Once the backing tape has been removed this adhesive pad will securely adhere the mount to your windscreen.

Note:

- Before removing the red backing tape from the adhesive pad make sure you have determined the optimum position for the Dash Cam and that the windscreen is free of dust and/or dirt.
- A spare adhesive pad has been provided, in case you wish to change the mounts location.

### 2. Lens

Wide Angle 140°, 6 Element glass lens for optimum picture quality.

### 3. Yellow LED indicator

This yellow LED indicator will flash (quickly) during formatting of the SD card.

**PARTS & CONTROLS (CONTD.)**

Back:

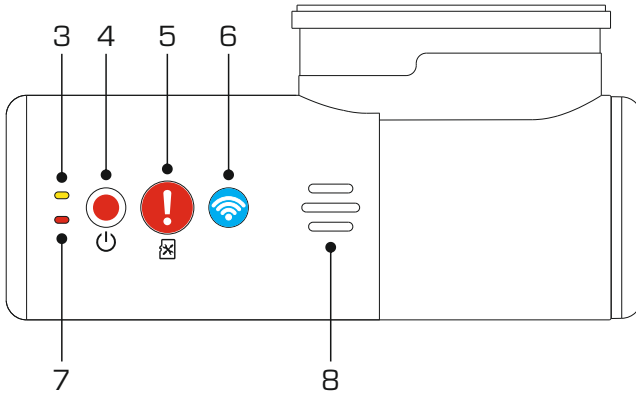
**4. Power & Record button**

Power:

Press and hold the button for 2 seconds to turn on and off the Dash Cam.

Record:

Press to start or stop a recording.

**5. Protect Recording & Format SD Card button**

Protect Recording:

Press the protect button whilst recording to protect the current recording, the button will illuminate, red in colour indicating the file is protected.

Depending on at which point during the current recording the file is protected, the Dash Cam will also save the previous or subsequent recordings, as follows:-

If the protection takes place during the first 3rd of the recording, the previous recording will also be protected.

If the protection takes place during the final 3rd of a recording, the next recording will also be protected.

Note:

- A marker will be seen on the recorded file, noting when the protection took place.

Format SD Card:

Press and hold for 5 seconds until the yellow LED begins to flash.

Note:

- For stable performance, it is recommended that you format the memory card every 2-3 weeks. Of course, you should only do this AFTER you've downloaded any files from the card that you may want to keep.



**PARTS & CONTROLS (CONTD.)**

Back:

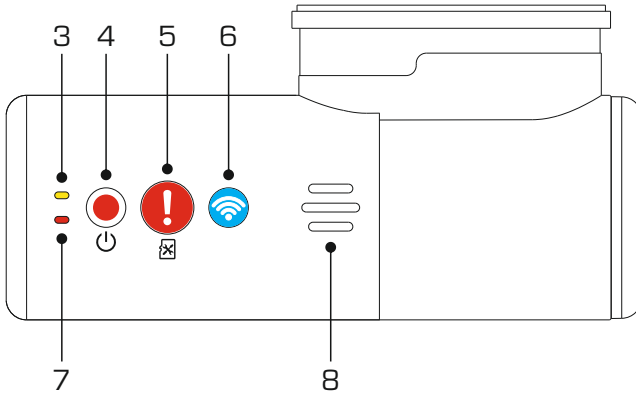
**6. Wi-Fi button**

Press and hold the Wi-Fi button for 2 seconds to turn on the Dash Cam's Wi-Fi function, a beep sound will also be when 'Sounds' are enabled.

Once turned on, the button will flash slowly blue in colour, awaiting a connection from a smartphone / tablet etc.

Once a device has been successfully connected the button will become solid blue.

If a connection is not established within 2 minutes, then the Wi-Fi function will turn off automatically and the blue flashing light will extinguish.

**7. Red LED indicator**

The red LED has three functions, as described below:

**Power**

The LED will be illuminate when power is connected to the Dash Cam.

**Recording**

During recording the red LED will flash.

**Firmware update**

During the firmware updating process, then red LED will flicker.

## PARTS & CONTROLS (CONTD.)

### 8. Speaker

Used for the two types of 'notification' sounds.

Sounds:

There are sounds, these are used to identify when recording starts / stops or has been protected.

1. Start recording  
A three-tone beep sound (ascending) will be heard when recording starts.
2. Stop recording  
A three-tone beep sound (descending) will be heard when recording stops.
3. Protected Recording  
A chime sound will be heard when a recording has been protected by activation of the G Sensor or by pushing the protect button.

Announcements:

There are two spoken announcements, these are used to identify there is an SD card issue that needs attention before recording can start.

- i. Please insert Class 10 SD card  
This is heard when there is no SD card inserted.
- ii. Card error, format SD card  
The inserted card has previously been formatted to an incompatible standard for use with the Dash Cam, this is usually resolved by simply re-formatting the SD card within the Dash Cam.

Or for some reason the card is unable to be formatted using the Dash Cam.

See page 40 for details on how format the SD card.

Note:

- Should formatting the SD card not resolve the issue, please try another quality branded SD card, making sure that is a Class 10 (48MB/s minimum) type.
- The Sounds and Announcements can be turned On / Off from the DriveGuard™ APP as required.

**PARTS & CONTROLS (CONTD.)**

Sides:

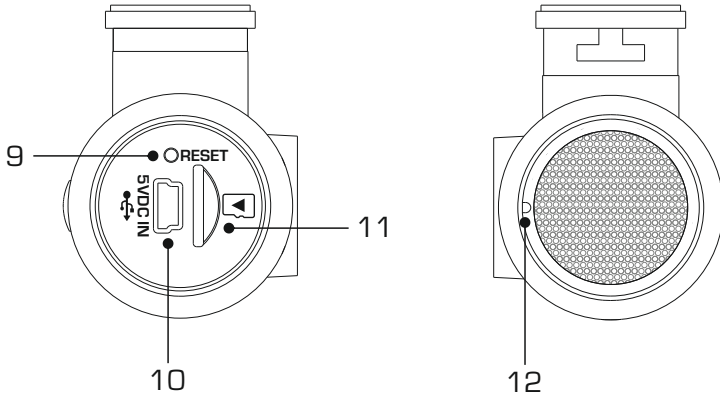
**9. Reset button**

In the unlikely event the Dash Cam becomes unresponsive, press the RESET button to restart the Dash Cam.

**10. DC-IN / USB socket**

Connect the supplied car power cable or USB data cable here.

**11. SD card slot**

Insert the MicroSD card here, taking care that the gold contacts are facing towards the Dash Cam's buttons.

**12. Microphone**

Integral microphone for audio recording, this can be turned off via the DriveGuard™ App.

## IN VEHICLE INSTALLATION

### 1. Download and install the APP

Visit the appropriate APP store for your smartphone / tablet and download the Nextbase DriveGuard™ APP.

Install the APP upon your device and then open the APP in readiness to connect to the Dash Cam.



Nextbase DriveGuard™ can be used to view and download video footage, report incidents to your insurer and change the settings on your Dash Cam.

## IN VEHICLE INSTALLATION (CONTD.)

### 2. Insert micro SD Card

Insert the MicroSD card here, taking care that the gold contacts are facing towards the Dash Cams buttons.

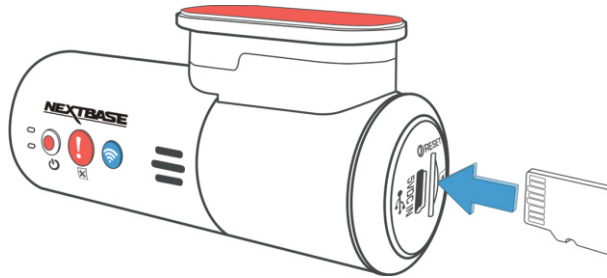

### 3. Connect power

Connect the supplied Car Power cable in to the Mini USB socket marked '5VDC IN'.

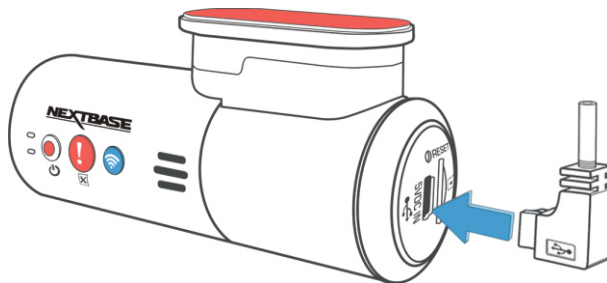

## IN VEHICLE INSTALLATION (CONTD.)

**4. Plug Cigarette Power cable in to the car power supply**

Connect the Cigarette lighter plug to the vehicles 12Vdc or 24Vdc supply.

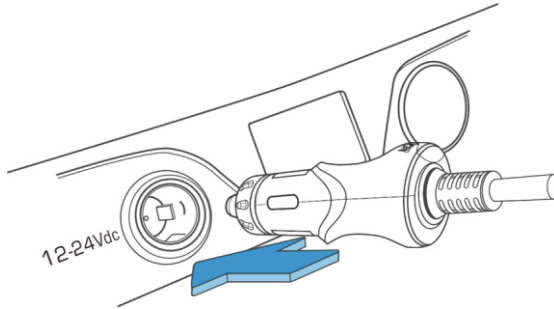

**5. Turn on Wi-Fi upon the 300W**

After the Dash Cam has powered on, then press the Wi-Fi button until the button starts to flash Blue in colour, to indicate that the Wi-Fi function is turned on and awaiting a connection.

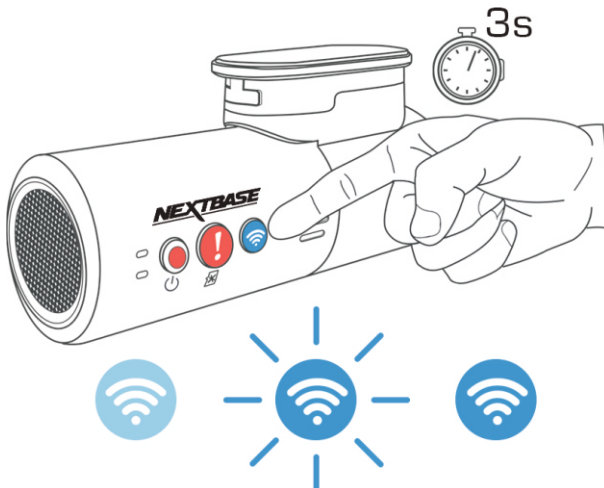

## IN VEHICLE INSTALLATION (CONTD.)

### 6. Connect Mobile Phone to the 300W

With the Nextbase DriveGuard™ APP working upon the Smartphone / tablet, press “Connect to Dash Cam” and then choose the 300W Dash Cam option. This will show the Live View image from the Dash Cam upon the DriveGuard™ APP.

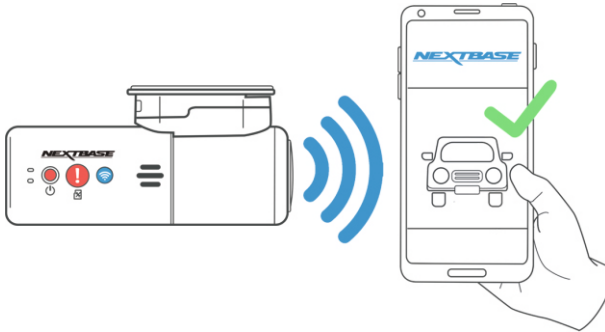

### 7. Remove the 3M protective sheet

Peel off the red layer to expose the 3M sticky pad beneath.

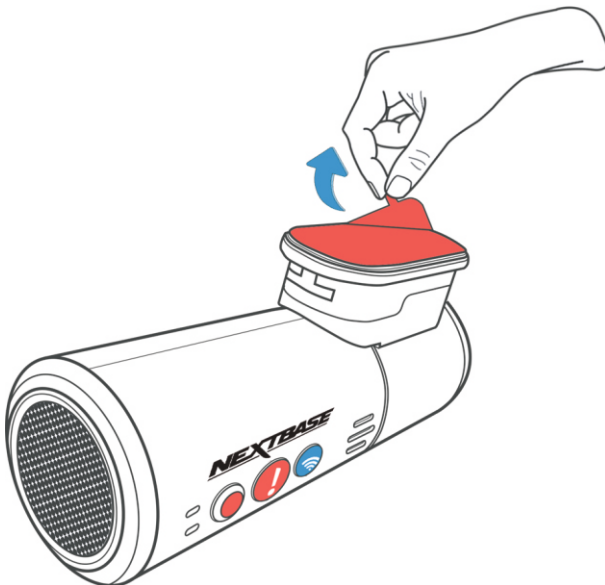

## IN VEHICLE INSTALLATION (CONTD.)

### 8. Locate and then check the 300W Dash Cam position using App

Offer the Dash Cam towards the windscreen whilst looking at the Live View on the connected Smartphone / Tablet. Ensure that the Live View shows the desired image by moving the Dash Cam to the best position possible on the windscreen and adjusting the lens accordingly.

Avoid any painted section of the windscreen being seen in the Live View and ensure the Dash Cam is mounted horizontally, with the smartphone image the right way up !

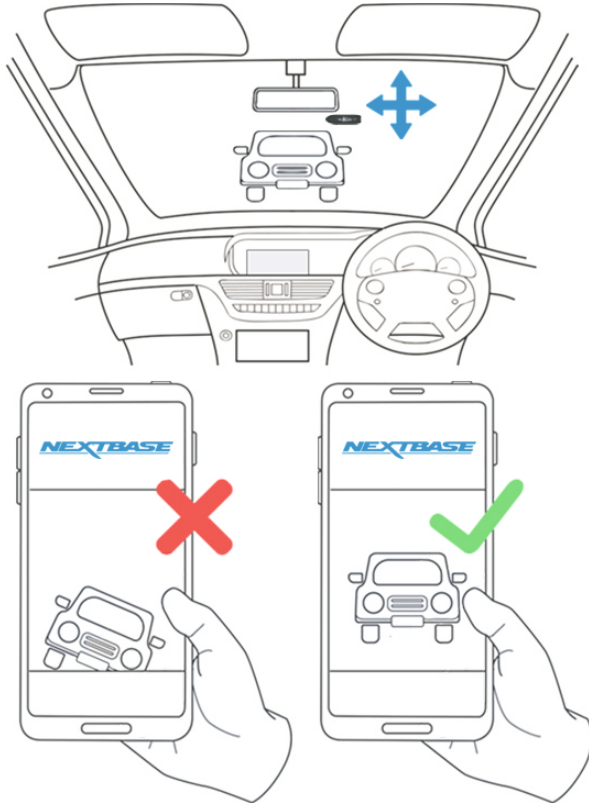



## IN VEHICLE INSTALLATION (CONTD.)

### 9. Apply mount to windscreen

Lightly press the mount against the windscreen and double check that the image as seen upon the smartphone / tablet is correct. Make any adjustments if required, prior to pressing the Dash Cam firmly against the windscreen to ensure that the 3M tape is securely attached.

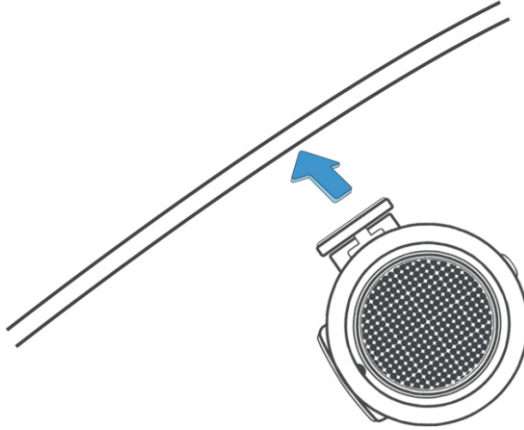

### 10. Adjust lens position as required

If any final adjustments to the lens position are required, then gently rotate the lens to the desired position using finger pressure, taking care not to touch the glass element of the lens itself.

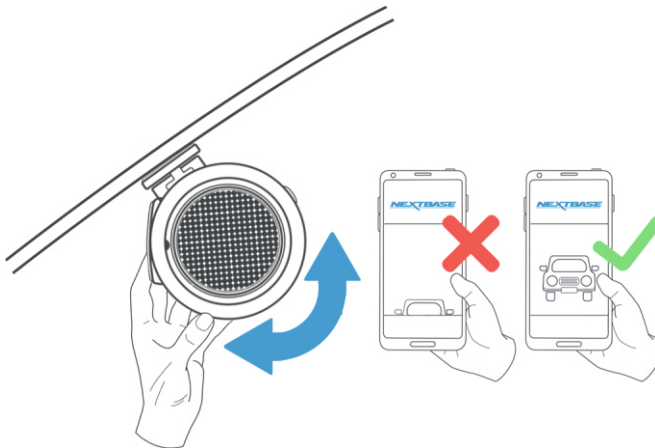

**IN VEHICLE INSTALLATION (CONTD.)**

Route the supplied car power cable (as shown) and connect it to the DC-IN socket of the mount.

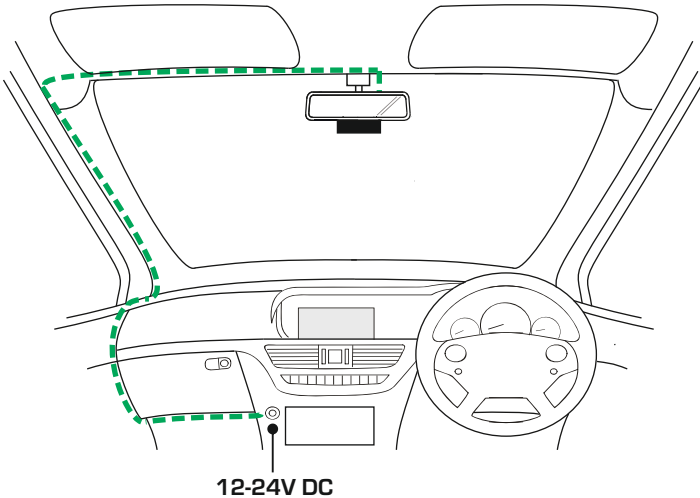

The above diagram is for illustration purposes only.

The Dash Cam will automatically power on and start recording once power is available. In some vehicles this will be when connections are made, for others the Dash Cam will power on once the ignition has been turned on.

If the vehicle in which the Dash Cam is installed has permanent live cigarette lighter sockets, the user can simply use the power button to switch the Dash Cam off when the vehicle stops. To take advantage of the Automatic Start / Stop Technology a Nextbase Hardwire Kit can be installed on a switched-live power supply.

The Nextbase Hardwire Kit includes the necessary 12-24Vdc to 5Vdc convertor and battery protection circuitry.

Should your vehicle not have a 12-24Vdc outlet, but does have a 5Vdc USB Outlet, this can be used instead. Connect the USB cable supplied with your Dash Cam in place of the car power cable.

**Note:**

- Do NOT wire the Dash Cam directly to a 12V supply by cutting the cigarette plug off the end of the cable, or damage will result.

## IN VEHICLE INSTALLATION (CONTD.)

Please read and follow the notes below for the safe operation of your Dash Cam within your vehicle.

As per the installation instructions, you must install the camera so it does NOT obstruct the drivers view of the road, preferably behind the rear view mirror.

Whilst the Dash Cam clearly needs to view through the windscreen in an area swept by the windscreen wipers, the Dash Cam should be installed so as not to intrude significantly within the wiped area.

A 40mm intrusion into the green wiped area is the maximum permitted by law.

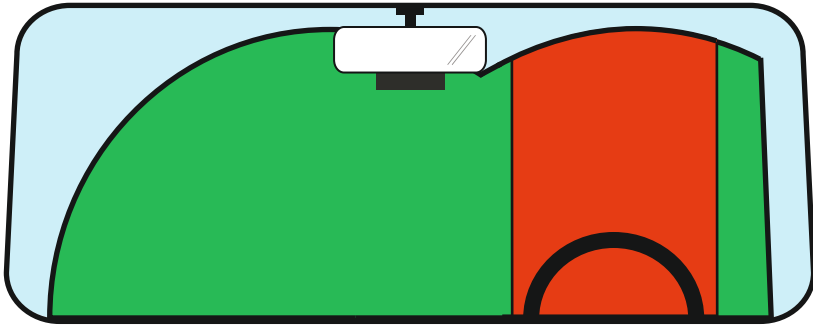

Do NOT mount the Dash Cam in front of the driver directly, as depicted by the red area in the above illustration.

When installing the Dash Cam in a vehicle, always place the device securely against the windscreen and where possible conceal the power cable under trim. Make sure that the Dash Cam power cable does not interfere with the drivers operating controls, such as the steering wheel, pedals or gear levers.

Do NOT mount the Dash Cam in front of an airbag field of deployment or in a position to obscure any mirrors.

Clean the windscreen at the point of location, prior to fitting the Dash Cam, to ensure absolute adhesion.

It is recommended NOT to operate the Dash Cam whilst driving.

The automatic Start-Stop technology incorporated within the device negates any need to operate the controls whilst driving.

Note:

- Adjust any settings or review recordings using the DriveGuard™ APP, whilst stationary, not whilst driving.
- Only use your smartphone / tablet whilst stationary, not whilst driving.

**For Help and Support please call 02920 866 429**

## DRIVEGUARD APP - INTRODUCTION

Nextbase DriveGuard™ is an APP specifically designed for use with the Nextbase range of Dash Cams and works with Android & iOS for use on Smartphones and tablets alike.

See Product Specification section for minimum Operating System requirements.

The APP allows you to watch the live view from your Dash Cam, make recordings, watch previous recordings and then download selected recordings accordingly. The recordings can then be used as evidence for any situation / incident or accident witnessed and can be shared accordingly.

The APP also allows you to make any changes required to the settings within the Dash Cam.

Nextbase DriveGuard™ APP is available freely to Download from your applicable APP store, as shown below:-



Please download, install and then run the APP, before continuing further with these instructions.

**For Help and Support please call 02920 866 429**

## DRIVEGUARD APP - VEHICLE INSURANCE DETAILS

### Enter your vehicle's insurance details

Once the DriveGuard™ App has been opened you will be prompted to enter your details relating to your vehicle insurance.

These are only used if and when you choose to use the 'Incident Reporting' function within the DriveGuard™ App.

Should you wish not to enter your details at this time then simply use the 'back' button on your handset, this will take you to the 'opening' screen.

You may also enter or change details at a later date, these can be accessed via the menu, by selecting 'Insurance Details'.

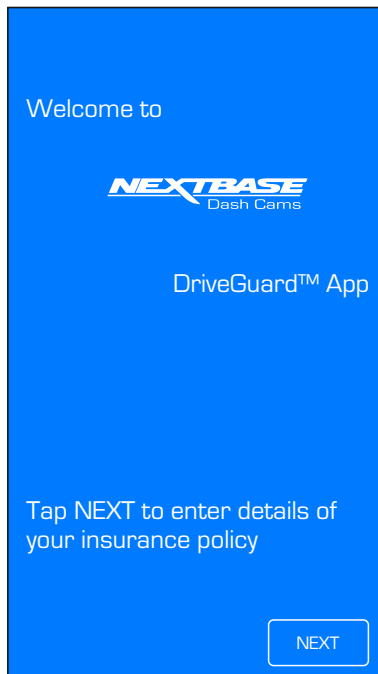

## DRIVEGUARD APP - VEHICLE INSURANCE DETAILS (CONTD.)

Continued from previous page.

If your Dash Cam is to be used in more than one vehicle then tapping the '+' button below the Vehicle 1 details will allow you to add additional vehicles.

Once you have entered all of your vehicle and insurance details you should tap 'Confirm' to proceed.

**NEXTBASE**  
Dash Cams

Please enter your details below as they appear on your insurance policy

First Name  
John

Surname  
Smith

Address  
1 Main Street

City  
Anytown

County  
Surrey

Postcode  
AB12 3XY

Telephone Number  
01234 5678910

Email Address  
JSmith@example.co.uk

NEXT

**NEXTBASE**  
Dash Cams

Please enter your vehicle details below as they appear on your insurance policy

Vehicle 1

Vehicle Registration  
ABCD 123

Insurance Provider  
Protectyourcar Insurance group

Policy Number  
0123456789



Add additional vehicles

BACK CONFIRM

## DRIVEGUARD APP - CONNECT YOUR DEVICE

### Connecting your mobile device to your Dash Cam

Once you have downloaded Nextbase DriveGuard™ for your mobile device, you will need to turn on the Wi-Fi function on your Dash Cam.

With the Dash Cam powered on, press and hold the  button until it starts to flash blue. The flashing indicates that the Wi-Fi function is turned on and awaiting a connection.

The Dash Cam will appear as NEXTBASE 300W xxx, within the available networks seen on your mobile device.

When you launch Nextbase DriveGuard™ you will see the Welcome Screen as shown below:-



Tap the **CONNECT TO DASH CAM** button and Nextbase DriveGuard™ will then open the Settings screen for your mobile device.

Connecting to the Dash Cam is the same process as you would use to connect your mobile device to any Wi-Fi 'network'.

Select 'NEXTBASE 300W xxx' from within the list of available networks and if prompted enter the default password '12345678'.

## DRIVEGUARD APP - HOME SCREEN

### Home screen

Once your mobile device is connected DriveGuard™ will display the Main screen and you will see a live image from your Dash Cam as shown below:-

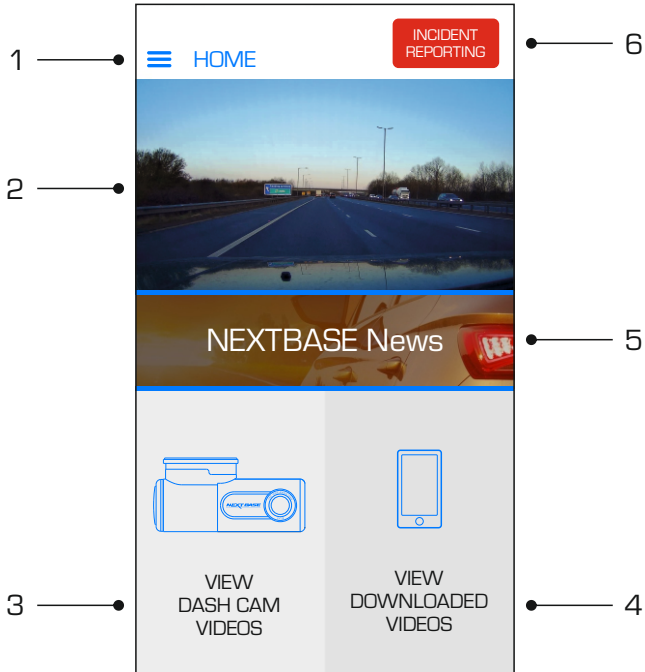

From within the Main screen you can select Live View, view recordings stored on your Dash Cam or recordings that have previously been downloaded to your mobile device. You can also access the Nextbase DriveGuard™ Menu options.

#### 1. Menu

Tap here to access the Nextbase DriveGuard™ Menu options, these include Dash Cam Settings.

#### 2. Live View

This window displays a live image from your Dash Cam. Tapping the Live View window will display the Live View full screen and allow you to stop and start recording

#### 3. View Dash Cam Videos

Tap here to view videos that are stored on your Dash Cam. You can then stream the videos directly from your Dash Cam or download them to your mobile device.



**DRIVEGUARD APP - HOME SCREEN (CONTD.)**

Continued from previous page.

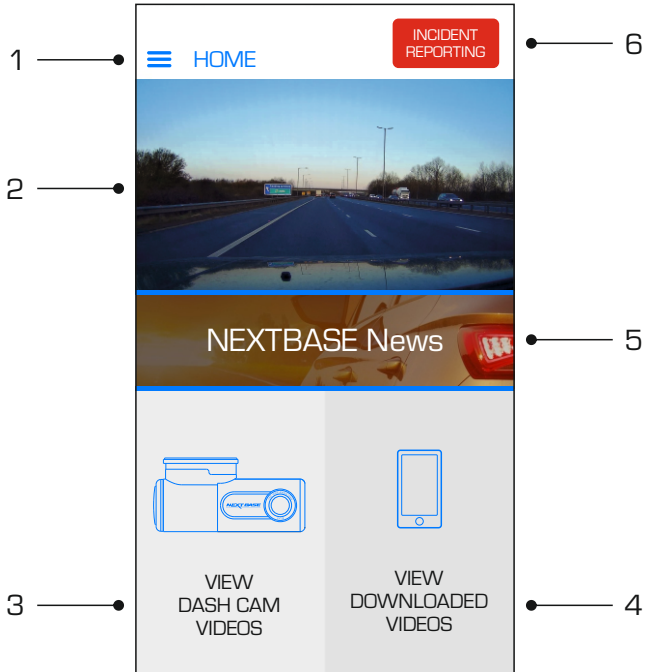
**4. View Downloaded Videos**

Tap here to view videos that have been downloaded from your Dash Cam to your mobile device.

You can then play the files on your mobile device or share them online

**5. NEXTBASE News**

Tap here to subscribe to the NEXTBASE UK news feed to keep up to date on new products and promotions.

**6. Incident Reporting**

Tap here to easily select, edit and upload recordings along with your insurance details.

## DRIVEGUARD APP - DOWNLOADING RECORDINGS (iOS)

### Downloading Videos from your Dash Cam (iOS)

To download files from your Dash Cam to your mobile device first tap on the View Dash Cam Videos button on the Main screen.

Nextbase DriveGuard™ will then display a list of videos stored on your Dash Cam as shown below:-

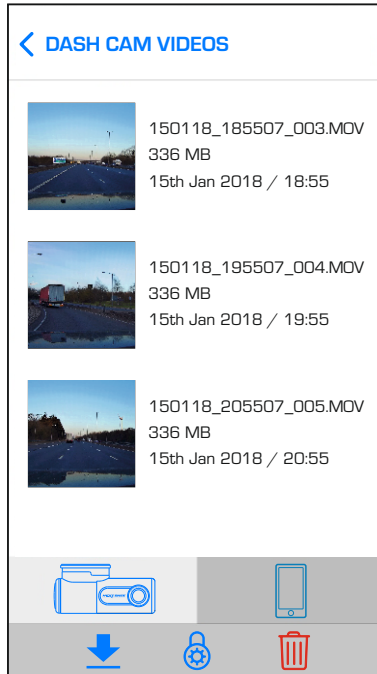

There are three buttons located at the bottom of the screen:-



Download files



Protect / unprotect files



Delete files

Tap the download files button and check boxes will appear next to each video, tap the videos that you wish to download and a tick will appear next to each selected video. You can tap a video a second time to deselect it.

When you have selected all of the files that you wish to download tap the Done button in the top right corner of the screen.

When you tap the Done button Nextbase DriveGuard™ will display the progress of your video downloads on screen, you can tap the progress indicator at any time to cancel the current downloads.

Once videos have finished downloading they will appear in the Downloaded Videos screen which can be accessed from the Main Screen

## DRIVEGUARD APP - DOWNLOADING RECORDINGS (ANDROID)

### Downloading Videos from your Dash Cam (Android)

To download files from your Dash Cam to your mobile device first tap on the View Dash Cam Videos button on the Main screen.

Nextbase DriveGuard™ will then display a list of videos stored on your Dash Cam as shown below:-

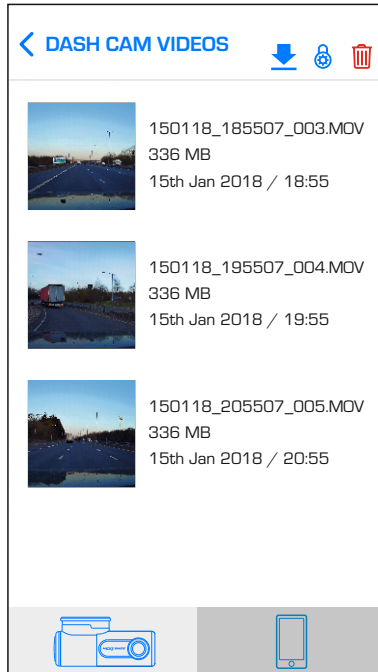

Tap and hold on one of the videos that you wish to download and check boxes will appear next to each video.

Tap the videos that you wish to download and a tick will appear next to each selected video. You can tap a video a second time to deselect it.

Three buttons will also have appeared at the top of the screen.



Download files



Protect / unprotect files



Delete files

When all of the videos that you wish to download are selected tap the Download Videos button. When you tap the Download Videos button Nextbase DriveGuard™ will display the progress of your video downloads

You can tap the Cancel button on the progress indicator at any time to cancel the current downloads.

Once videos have finished downloading they will appear in the Downloaded Videos screen which can be accessed from the Main Screen.

## DRIVEGUARD APP - EDITING RECORDINGS

Use DriveGuard™ to edit your downloaded recordings

To edit a video that you have downloaded to your mobile device first tap on the recording that you wish to edit on the Downloaded Videos screen.

The video will begin to play allowing you to confirm that you have selected the correct video. Next, tap the Menu button in the top right corner of the Video Playback screen and then tap 'Edit video'

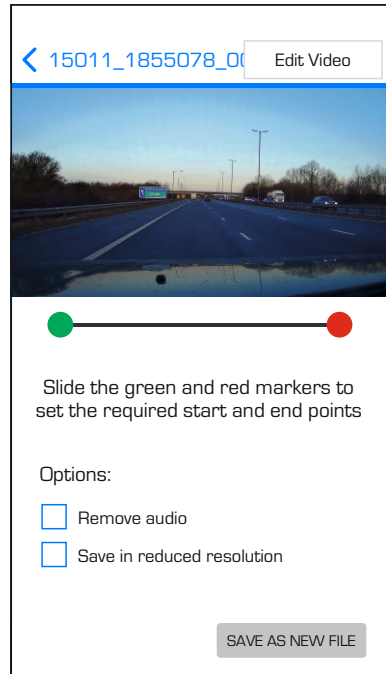
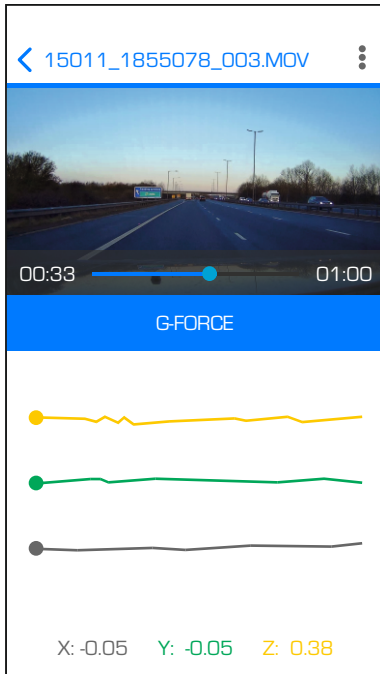

Continued on next page.

## DRIVEGUARD APP - EDITING RECORDINGS (CONTD.)

Continued from previous page

From within the Edit Video screen trim videos and remove audio from your video footage.

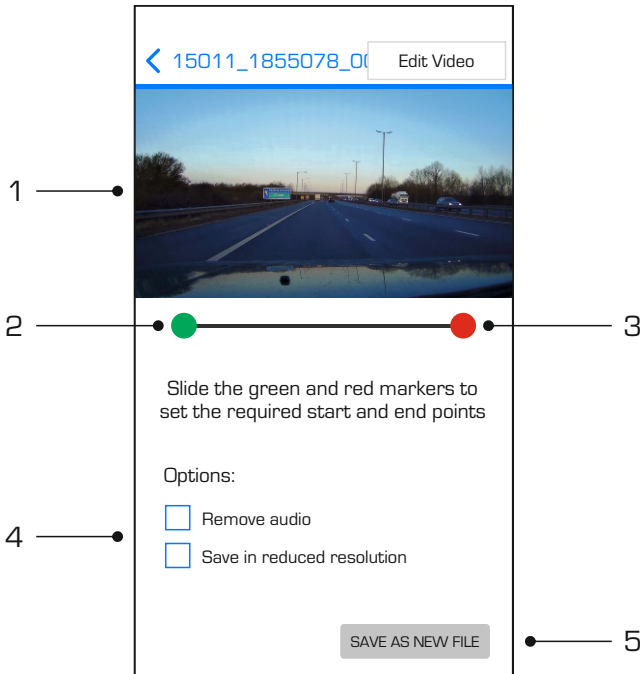

### 1. Video Window

Displays a preview of your video whilst editing. Image will update as markers are moved

### 2. Start Marker

The green Start Marker indicates the position where you would like your trimmed file to begin. Drag the marker to adjust the beginning of the trimmed file.

### 3. End Marker

The red End Marker indicates the position where you would like your trimmed file to end. Drag the marker to adjust the end of the trimmed file.

### 4. Options

Allows you to select additional editing options

### 5. Save Button

Tap the Save button to confirm the changes that you have made and save a new video file. The saved file will be seen in the 'DOWNLOADED VIDEOS' directory and easily identifiable, as 'TRIM' will be within the file name.

## DRIVEGUARD APP - SHARING RECORDINGS

### Sharing recordings

Once you have downloaded videos from your Dash Cam to your mobile device it is then possible to Share your videos online. In order to do this you will need to disconnect your mobile device from your Dash Cam Wi-Fi connection and connect to your usual Wi-Fi connection with internet access.

You should then tap on the View Downloaded Videos button on the Nextbase DriveGuard™ Main screen.

The Downloaded Videos screen shows all videos that you have downloaded from your Dash Cam and functions in the same way as View Dash Cam Videos screen, however the Download button is replaced with a Share  button, see below:-

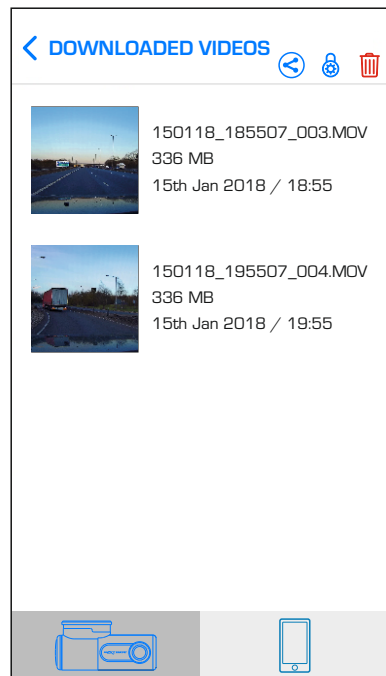
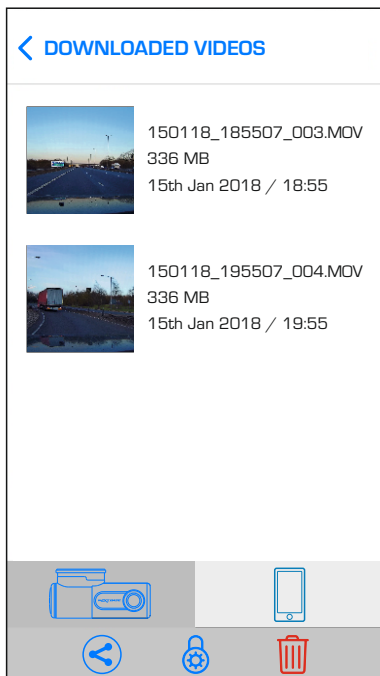

Tapping the Share button when files are selected will display the sharing options available on your device. This will include social media applications if installed on your device such as Facebook, YouTube or Twitter as well as the option to use Nextbase Private Share. Nextbase Private Share will allow you to upload your videos to the Nextbase Servers and when upload is completed you will be given a link which you can then send to friends or your insurance company allowing them to watch your video online.

**Note:**

- The link will expire after 30 days and the video will be deleted from the Nextbase Servers.

## DRIVEGUARD APP - INCIDENT REPORTING

### Incident Reporting

The DriveGuard™ App has been designed to allow the easy sending of files to your insurance company. Tap the 'INCIDENT REPORTING' button to select, edit and upload the recording to our secure server.



Once this has been done then you will receive an email which contains a link to download the recording, this email can then be sent on to your insurance company.

See following pages for step-by-step instructions for the INCIDENT REPORTING process.

## DRIVEGUARD APP - INCIDENT REPORTING (CONTD.)

### Incident Reporting - Step 1: select the recording that captured the incident

Select the location of the recording that you wish to send to your insurance company, this will be in either the 'Video saved on Dash Cam' or 'Video downloaded to mobile Device' directory.

Select the required location and then the recording that you want to send to your insurance company.

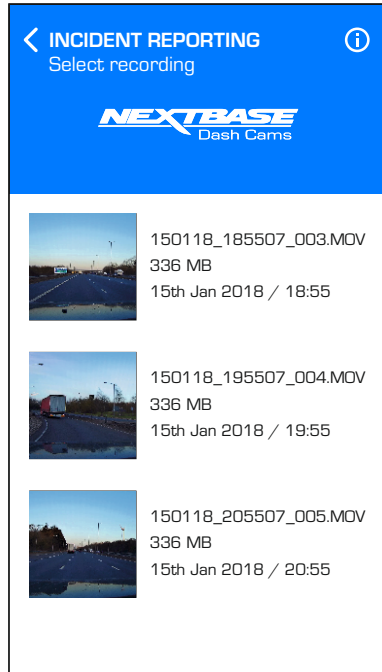
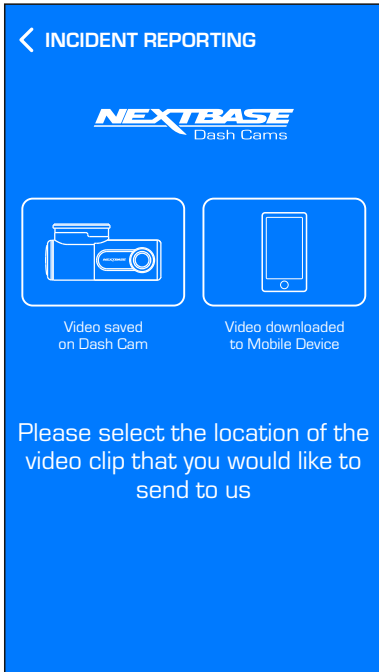

If the recording is currently saved in the 'Video saved on Dash Cam' directory it will automatically download to the 'Video downloaded to mobile Device' directory, this then allows the editing and uploading of the recording.

Once the download has been completed the 'editing' screen will open



## DRIVEGUARD APP - INCIDENT REPORTING (CONTD.)

### Incident Reporting - Step 2: edit the video

The recording can be edited to reduce its file size, a smaller file size is preferable when uploading and downloading the recording.

This is achieved by 'trimming' the recording, i.e. removing unwanted content from before and after the incident.

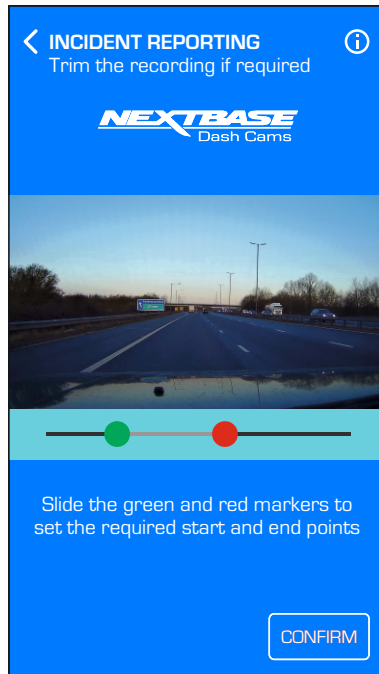

To trim the video use the GREEN button to select the new start point and the RED button to set the new end point of the recording.

Once you are happy with the trimming press the CONFIRM button to move onto the next step.

## DRIVEGUARD APP - INCIDENT REPORTING (CONTD.)

### Incident Reporting - Step 3: confirm your contact details

If you entered your insurance policy details the first time you opened Nextbase DriveGuard™ then the details that you entered will now be displayed. If your details are incorrect or incomplete then tapping the EDIT button will allow you to amend your details.

Once your insurance policy details are correct you should tap the Confirm button to continue. Your video will now begin uploading the Nextbase Secure Server. When the upload is completed an email will be sent to the email address provided in your insurance policy details. The email will contain a link to your video along with your insurance policy details.

← INCIDENT REPORTING  
Confirm your contact details

**NEXTBASE**  
Dash Cams

Your clip is now ready to send to us. Please check your details below before confirming.

First Name  
John

Surname  
Smith

Address  
1 Main Street

City  
Anytown

County  
Surrey

EDIT      CONFIRM

← INCIDENT REPORTING  
Send the video to your insurer

**NEXTBASE**  
Dash Cams

Your video clip is now being uploaded. When the upload is completed an email will be sent to the email address that you have provided containing a link to your video, along with the insurance details that you have provided.

You can then forward this email to your insurance provider.

CLOSE INCIDENT REPORTING

## DASH CAM SETTINGS

The Dash Cam settings are accessed via the DriveGuard™ App, tap the '☰' button to open the menu. From the menu select 'Dash Cam Settings'.

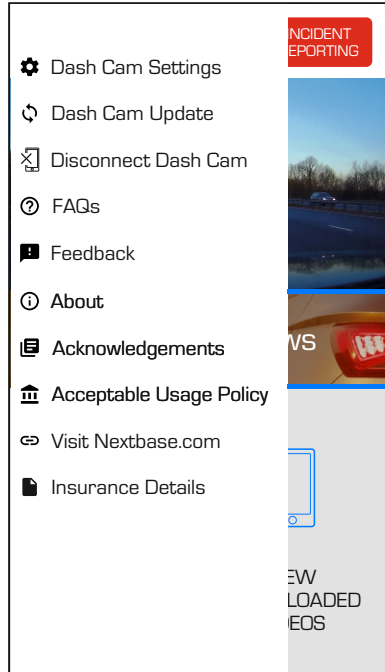

See following pages for full details of the various settings available.

**Note:**

- Some settings may not be available depending on which iOS / Android version your mobile device is using.

## DASH CAM SETTINGS (CONTD.)

Video menu:

The default settings have been carefully selected to allow you to use the Dash Cam without the need to change any settings. However, should you wish to change a setting then please see below.

Note:

- Menus are not accessible whilst the Dash Cam is recording.

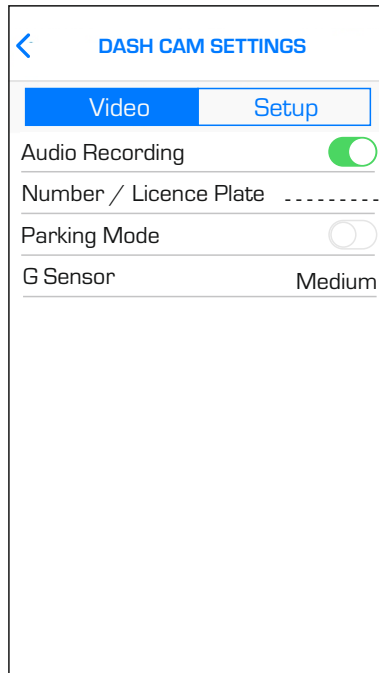

### 1. Audio Recording

Turn On / Off the microphone.

Options: On and Off  
Default Setting: On

### 2. Number / Licence Plate

Enter the registration number for your vehicle, this will then be shown on the video file.

## DASH CAM SETTINGS (CONTD.)

Video menu continued:

### 3. Parking Mode

There is only one method of using parking Mode, which is by using a 'Permanent Live'.

This means that there is always 12Vdc being supplied to the Dash Cam. This can either be by using a 12Vdc outlet that does not power off when the vehicle's ignition is turned off or by using the Nextbase Hardwire Kit which has been installed using a permanent live fuse location.

Once Parking Mode has been turned on, the Dash Cam will enter standby mode when there is no physical movement detected for a 5 minute period.

Should physical movement of the vehicle be detected, the Dash Cam will power on and start recording a 1 minute protected video and then will continue to record normally until there is no physical movement detected for a 5 minute period.

### 4. G Sensor

Turn off or adjust the sensitivity of the built in G Sensor. The G Sensor detects forces which will automatically protect the current recording in event of a collision.

Note:

- This does not affect Parking mode sensitivity.

Options: High, Medium, Low and Off

Default Setting: Medium

## DASH CAM SETTINGS (CONTD.)

Setup menu:

The default settings have been carefully selected to allow you to use the Dash Cam without the need to change any settings. However, should you wish to change a setting then please see below.

Note:

- Menus are not accessible whilst the Dash Cam is recording.

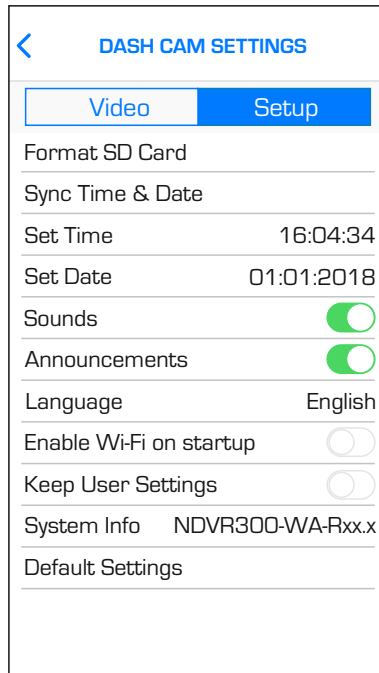

### 1. Format SD Card

Format the inserted memory card. This will delete all content upon the SD card.

The SD card can also be formatted by pressing and holding the Protect button for 5 seconds, the yellow LED indicator will flash (quickly) during formatting.

Note:

- For stable performance, it is recommended that you format the memory card every 2 weeks.

Of course, you should only do this AFTER you've downloaded any files from the card that you may want to keep.

## DASH CAM SETTINGS (CONTD.)

Setup menu continued:

### 2. Sync Time & Date

This function can be used to synchronise the time and date on the Dash Cam to that of your connected device.

### 3. Set Time

This setting allows you to set the Time manually, if required during initial setup.

### 4. Set Date

This setting allows you to set the Date manually, if required during initial setup.

### 5. Sounds

Turn Off / On the device sounds, these will cancel the notification Sounds and the Startup & Shutdown chimes.

Options: On and Off  
Default Setting: On

### 6. Announcements

Turn Off / On the spoken announcements, these are heard when there is no SD card inserted or the SD card has an error and needs to be formatted using the Dash Cam.

Options: On and Off  
Default Setting: On

### 7. Language

Select preferred language for the spoken announcements.

Options: English, Danish, German, Spanish, French, Italian, Dutch, Norwegian, Finnish and Swedish  
Default Setting: English

### 8. Enable Wi-Fi on startup

Once enabled the Dash Cam's Wi-Fi will turn on automatically when the Dash Cam starts up.

The Dash Cam's Wi-Fi will be seen as an Access Point (hotspot) by your mobile device, depending on the settings within your device it may automatically connect to the Dash Cam. This may leave you without a cellular connection.

Options: On and Off  
Default Setting: Off

Note:

- Depending on your mobile device a Cellular connection may not be available during Wi-Fi connection to the Dash Cam, hence the recommended setting is off.

## DASH CAM SETTINGS (CONTD.)

Setup menu continued:

### 9. Keep User Settings

Turn this to ON in order to keep your individual user settings during the Dash Cam Update process.

Select OFF in order to clear all user settings and return them to defaults, during the Update process.

Options: On and Off

Default Setting: Off

### 10. System Info

Use this function to view the available System Information, tap the screen for details.

The Model number and installed Firmware version of your Dash Cam.

FCC-ID is shown here under the E-Label Act (USA).

SD Card Information is provided for the installed SD card within the Dash Cam

Wi-Fi Information is provided for the Dash Cam:

SSID (network name), Password and MAC address.

### 11. Default Settings

Reset the Dash Cam to the default settings.



## HOW TO FORMAT THE MEMORY CARD

Formatting the SD card

Every 2-3 weeks we recommend that you reformat the memory card, using the Dash Cam. This will wipe any files from the card and set it up afresh for continued use with your Dash Cam.

Of course, you should only do this AFTER you've downloaded any files from the card that you may want to keep, as formatting the card will remove all content.

There are two methods of formatting the SD card available:

1. Using the Dash Cam buttons

Press and hold for red button for 5 seconds until the yellow LED begins to flash, once formatting is completed the LED will stop flashing.

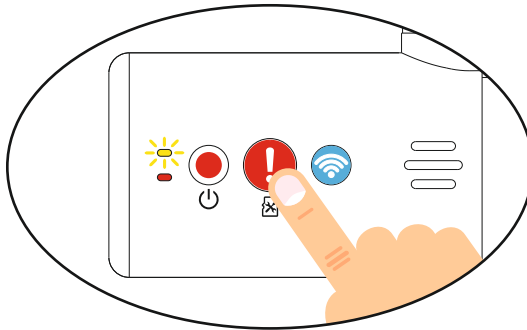

2. Using the DriveGuard™ App on your connected device

Open 'DASH CAM SETTINGS' from the DriveGuard™ home screen by tapping the '☰' button.

Select 'format SD Card' and follow the on-screen instructions.

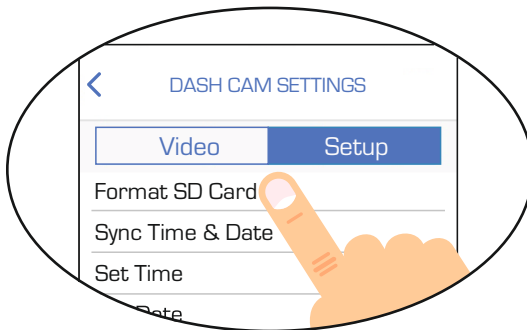

## PC CONNECTION

The dash cam has two available modes when connecting to a computer, these are:

### **Mass Storage Mode (Windows and Mac)**

This mode is used to view, edit and share recordings using NEXTBASE Replay 3 playback software on your computer.

Note:

- Mass Storage mode is 'read-only', this means that content on the SD card can only be read, not updated or erased.

### **Update Mode (Windows and Mac)**

This is used to Update the firmware on your Dash Cam, using NEXTBASE Replay 3.

Please see details within the NEXTBASE Replay 3 Playback software for more information.

Note:

- Update mode is 'read+write', this means that content on the SD card can be updated and erased. This in turn lets NEXTBASE Replay 3 write the new firmware to the SD card, allowing the automatic update to take place.

### **Connecting the Dash Cam to your computer**

Connect the supplied USB cable to the Dash Cam and then to your computer.

Once connected the Dash Cam will power on and automatically enter Mass Storage mode, this can be identified by the Protect Button flashing red.

To connect the Dash Cam in Update mode, press and hold the Protect button during connection of the USB cable. Release the button once the Wi-Fi button flashes blue.

Note:

- ALWAYS turn off the Dash Cam before disconnecting from your computer.

# Declaration of Conformity

**We, Portable Multimedia Limited.  
Dorna House Two,  
52 Guildford Road,  
West End, Surrey,  
GU24 9PW  
United Kingdom**

---

Declare under sole responsibility that the products:-

Product Name:           NEXTBASE In Car Cam  
Model number:         NBDVR300W

To which this declaration relates, is in conformity with the following standards,

EN 55032:2015  
EN55035:2017  
EN 61000-3-2:2014  
EN 61000-3-3:2013  
IEC 61000 -4-2:2008 IEC61000-4-3:2006+A1:2007+A2:2010  
IEC 61000-4-4:2012, IEC 61000-4-5:2014, IEC 61000-4-6:2013, IEC-4-8:2009  
IEC 61000-4-11:2004+A1:2017  
EN 62479:2010  
EN 301 489-1 V2.2.0: 2017-03  
EN 301 489-3 V2.1.1: 2017-03  
EN 301 489-17 V3.2.0:2017-03  
EN 300 328 V2.1.1: 2016-11  
EN 60950-1: 2006 + A11:2009+A1 2010+A12:2011+A2:2013  
2011/65/EU & 2015/863 (RoHS directive)  
2012/19/EU (WEEE Directive)  
EC 1907/2006 (REACH)

Supplementary information:

This product complies with the requirements above and carries the CE mark accordingly.

Caerphilly, United Kingdom  
(Place of issue)

15<sup>th</sup> Aug 2018  
(Date of issue)

Graham Lambert  
(Name of authorised person)

*G. K. Lambert.*  
(Technical Director)  
(Signature of authorised person)  
Telephone +44 2920 866429

Declaration of Conformity

## TROUBLE SHOOTING

PROBLEM	SOLUTION
The mount will not stay in place upon my windscreen.	Ensure that the red protective cover (plastic film) has been removed from the mount pad. Make sure that the glass is smooth and clean. Press the mount firmly to the glass ensuring that there is 100% contact with the glass. This can easily be seen from outside the windscreen, as contact area of the pad turns a darker colour. If the mount pad has lost it's sticky qualities, change the pad for the spare item contained within the box.
I cannot insert the MicroSD card.	MicroSD card are very small and require delicate use. Align the card with the diagram shown upon the Dash Cam and insert the card until you feel a slight spring resistance. You now need to push the card, using your finger nail, until you hear and feel a small latch. Release pressure and the card will stay retained within the device. Use the edge of a small coin if you have difficulty.
I cannot remove the MicroSD card.	With the card previously installed, you now need to push the card further inwards slightly, using your finger nail, until you hear and feel a small latch. Use the edge of a small coin if you have difficulty. Release pressure and the card will spring out sufficiently for you to take hold of it.
I can only record a few minutes of video on my MicroSD card.	Replace the Class 10 type MicroSD card with a new quality branded card. Max 128GB. Ensure to format the new SD card from within the Dash Cam.
I cannot save files to the memory card when the Dash Cam is connected to my computer under Mass Storage mode.	Correct, the Dash Cam is a 'read-only' device. It is not recommended to save files from other sources to the same memory that you will use for recording within the Dash Cam, as these may have a negative effect on the performance of the Dash Cam.
No power to my Dash Cam, but it works upon my PC.	The cigarette power cable is not working. Inspect the fuse in the Car Power plug. Replacement fuse = 2A 20mm type. If the fuse is found to be blown, inspect the power cable for damage which may have caused the fuse to blow.
My Dash Cam shuts down by itself after a while.	Either there is no power to the Dash Cam or Parking Mode has been turned on and no vehicle movement has been detected for 5 minutes.
I get the announcement "Card Error. Please format SD card".	The SD card has been formatted in another device and the Cluster Size is not compatible. There may also be an error on the card. Use the Setup option within the APP to re-format the SD card from in the Dash Cam. Ensure that the SD card is a Class10 type SD card of 8-128GB
The SD card in my Dash Cam cannot be read.	Use a good quality branded SD card between 8GB and 128GB Class 10 and format the card from within the Setup Menu of the APP.
I can't delete files on my SD card within the Dash Cam.	Check to see if these files are 'protected', if so please follow instructions to 'un-protect' the files within the APP.

## TROUBLE SHOOTING (CONTD.)

PROBLEM	SOLUTION
Mass Storage function does not work.	The Mass storage function will work on both Windows and Mac. Restart the PC, as this may be required for the necessary driver to be loaded correctly. Disconnect and reconnect the Dash Cam. Contact NEXTBASE for the required driver.
Video files cannot be played.	The video files from the Dash Cam are in .MOV format and may not be compatible with your PC if suitable playback software is not installed. Install the Nextbase Replay 3 playback software which is freely available from <a href="http://www.Nextbase.co.uk">www.Nextbase.co.uk</a>
Video Image is blurred.	Remove the protective lens cover and check that the Dash Cam field of view does NOT include any painted section of the windscreen. Clean the lens, clean the windscreen!
Video file playback is jumpy.	Reformat the SD card to remove non-contiguous files. For best recording use a quality branded Class 10 SD card of 8 to 128GB recommended size. PC may not be sufficient for the playback task, try a different PC. Copy the recorded video files onto the PC / Mac for playback directly rather than use the Dash Cam as a card reader.
The sound is not synchronised with video during playback.	The Codecs upon your PC may not be compatible or the latest standard. Download the latest Codecs from: <a href="http://www.nextbase.com">www.nextbase.com</a>
Video has no sound.	Ensure that "Audio Recording" setting is turned ON within the Setup menu of the Dash Cam.
I have turned on 'Parking Mode' and now can't stop the recording.	The Dash Cam will start a recording whenever motion is detected. To turn off Parking Mode firstly shutdown the Dash Cam and remove the SD card, this will avoid recording being activated accidentally. Switch the Dash Cam On and connect to your mobile device using the DriveGuard™ APP. Within the Dash Cam Setup Menu, turn off the 'Parking Mode'.
When I get in to my car, the Dash Cam is already recording and the file is protected.	This is normal. Parking Mode has been switched on and the Dash Cam has sensed vibration and has started to record correctly. Parking mode can be turned off within the Setup, Video menu if required.
Downloading files from <a href="http://www.nextbase.com">www.nextbase.com</a> using Google Chrome results in a Malicious Software message.	This is not a cause for concern, simply go to the settings within Google Chrome and turn off the malicious software protection temporarily to download and install the playback software. Reinststate previous Google Chrome settings thereafter.
My Mobile Device will not connect to my Dash Cam.	Please ensure that you have turned the Dash Cam Wi-Fi Mode on by pressing the Wi-Fi button until it starts to flash. When Wi-Fi Mode is turned on the Blue Wi-Fi button will either flash when waiting for a connection, or be solid blue once connected to your mobile device.

## TROUBLE SHOOTING (CONTD.)

PROBLEM	SOLUTION
The NEXTBASE DriveGuard™ app will not open.	Please uninstall the NEXTBASE DriveGuard™ app and re-download again from your devices App Store.
When I open the NEXTBASE DriveGuard™ App I get a message saying 'Please Check Device'.	Ensure that the Dash Cam is in Wi-Fi Mode and that your mobile device has connected to the Dash Cam Wi-Fi network.
When I try to play back a file from my Dash Cam I get a message saying 'Buffering' or a spinning circle, but the video does not load.	Please restart your mobile device and reconnect to the Dash Cam Wi-Fi network, then re-open the DriveGuard™ App.
I have forgotten my password for the Wi-Fi connection.	The password is a primary measure to ensure the privacy of your recordings and to prevent misuse of the Dash Cam. If the password has been changed from default and then forgotten, then the Dash Cam will need to have new firmware installed to reset the password (and all other settings) back to the defaults. Visit <a href="http://www.nextbase.co.uk">www.nextbase.co.uk</a> for product firmware and instructions upon how to perform the update.
Card full and card error message.	Is a branded card that is compatible with loop recording being used? This issue can occur if a counterfeit, slow or unbranded SD card is being used.
No mass storage option.	Try multiple USB ports and an alternative mini USB cable (if possible), please ensure it is inserted into the USB port on the Dash Cam and not into the mount.
Juddering image.	This is usually caused by a PC that is not compatible with HD or Ultra HD playback, we recommend an i5 or equivalent to play the files and metadata effectively.
Unresolved issues.	Reset the Dash Cam to the Default Settings within the Setup Menu and try again. Should the problem persist call the UK helpline (02920) 866429 or call your local support centre found at <a href="http://www.nextbase.com">www.nextbase.com</a> Alternatively email: <a href="mailto:support@nextbase.com">support@nextbase.com</a>

***NEXTBASE***<sup>®</sup>

[www.nextbase.com](http://www.nextbase.com)

